

A low cost node based on CAN I/O Expanders to detect people on escalators and moving walkways.

F.F. Linera, F.J. Garcia Navas, J. Cardesin, J. Martín & F. Nuño
DIEECS -Universidad de Oviedo. Gijón, SPAIN

Safety standards oblige to know the presence of people inside an escalator and moving walkways before changing its operation state. A photoelectric curtain based on emitter/receiver photocells is a good low cost solution. As a pair of emitter/receiver must be positioned every 30 cm along the escalator, the number of detectors increases greatly in long type conveyors and also increases the assembly and wiring cost.

This paper shows a solution based in a CAN slave node network distributed along both balustrades of the conveyor (Figure 1). Every CAN slave node is based on a low cost CAN Input/Output Expander chip and controls a set of detectors (emitters or receivers). There is also a master CAN node based on a PIC microcontroller that treats all messages information received from the slave CAN nodes and controls a safety relay that informs to the motor drive controller.

1. Introduction

Escalator and moving walks manufacturers have been obligated to include passenger sensor systems in order to avoid falls and injuries to people who are passing through the conveyor during an automated start or stop process. OTIS, KONE or MITSUBISHI are important companies of the conveyor sector that have several patents to solve this problem [1-3], but neither of them has a patent solution based on CAN. UNE-EN115 defines the requirements of these passenger sensor systems and obliges to detect an opaque 30 cm diameter cylinder situated on it.

A low cost solution for the system is based on a distributed network of photoelectric detectors positioned through the balustrades. These photoelectric detectors are normally based on emitters and receivers of barrier type, creating a light detection curtain along the length of the escalator or moving walk. This detector system must send the information to the motor drive controller, which must be considered during a start-up or stop process.

To fulfill EN115 a pair of emitter/receiver must be positioned every 30 cm and the number of detectors can be increased greatly in long type conveyors. The wiring assembly process and the signal transmission begin to be complicated in long escalators or moving walkways. Moreover, important safety requirements must also be fulfilled. For instance, if some photoelectric emitters or receivers are not operating appropriately, it must be detected by the system and it must indicate as if passengers are detected in the conveyor to avoid a dangerous start-up or stop. Also, if some type of communication network is included, it must be tested quite frequently to avoid that some communication problem causes a dangerous situation

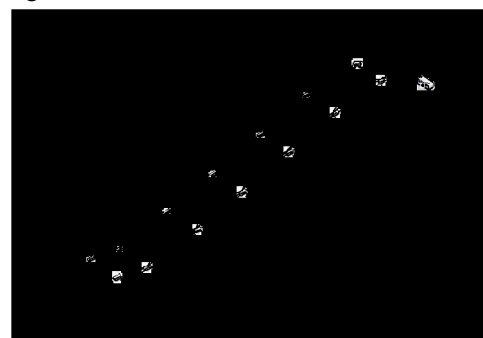

Figure 1: A cut-away view of an escalator with the channel cover removed

2. A passenger detection system overview

Figure 2 shows a plan view of a moving walk showing in a schematic form how all parts of the implemented solution are connected. It is based on a MASTER NODE which is communicated using CAN with several SLAVE NODES. There are two types of slave nodes: one type for controlling up to four photoelectric emitters and another to control up to four photoelectric receivers.

The core of the system is an embedded master node. It is communicated through the CAN bus with the emitter and receiver nodes. The Master node treats the received information in order to decide if the conveyor is free of passengers or not. The main simple way to translate this result to the main motor controller (PLC) is through an opened or closed safety relay contact. In order to fulfill safety standards applied to escalators and moving walks, this normally open contact must be implemented connecting in series two safety relay contacts.

In the first implementation for this master node, a solution based on a Mid-Range 8-bit PIC16 microcontroller with two different stand-alone CAN controllers was chosen. Separated CAN buses were also used for emitter and receiver networks. Recent implementation uses PIC18 microcontroller with integrated CAN controller and a unique CAN bus for emitter and receiver networks.

Due to the requirements, the firmware programmed in this microcontroller is quite complex and it will be described in the fourth point of this paper.

The receiver and emitter slave nodes are based on MICROCHIP CAN I/O expanders as it will be described in the third point of this paper. Use of CAN I/O expanders will reduce notably the system cost, although the processing properties of the node are less than if a small microcontroller were used on it.

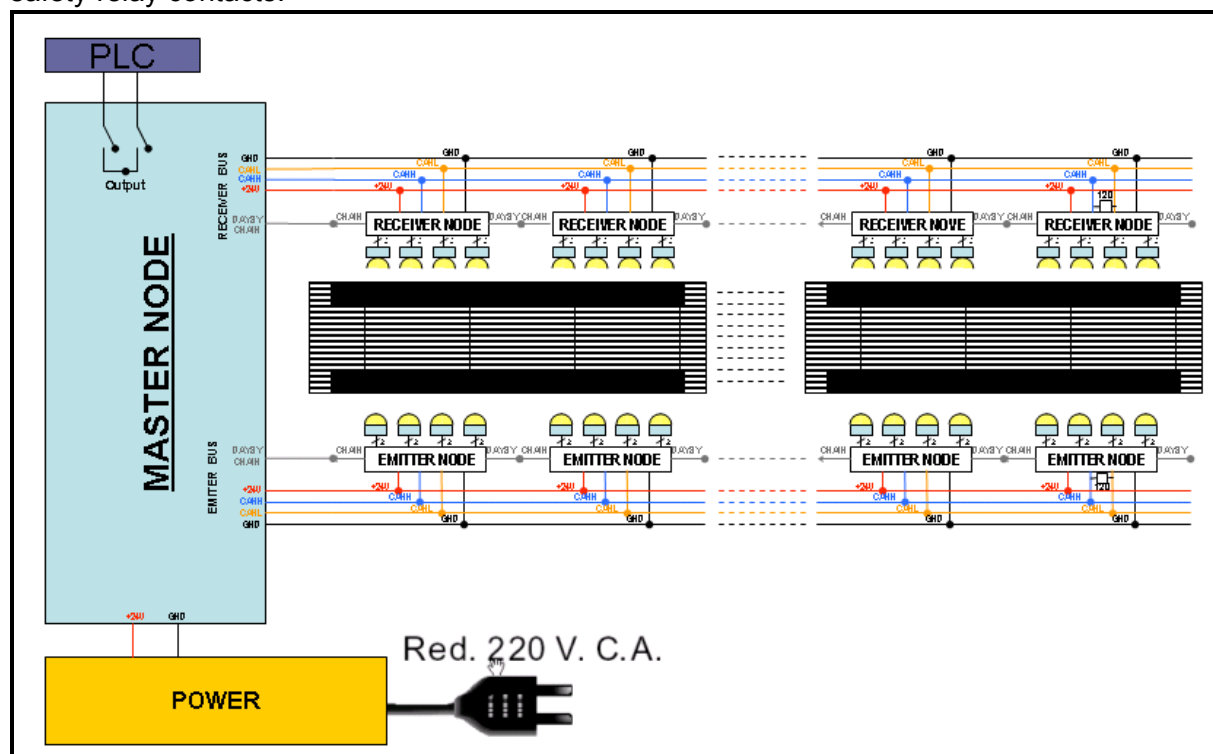

Figure 2: A plan view of a moving walkways showing the situation of the main parts.

Another important requirement for the CAN slave nodes is that all emitter nodes and all receiver nodes must be programmed with the same firmware initially. It makes the assembling process in the conveyor mounting easier. It also simplifies the reparation by the maintenance team.

Nevertheless, during the start-up process the slave CAN nodes are re-programmed with individual identifiers using CAN messages sent by the master node. To make it possible, a five pole wire was used for the communication of the master node with the slave receiver and emitter nodes. Four wires are easy to justify: two wires are used for the supply source and other two wires are for the CAN bus. The fifth wire was necessary to implement the re-programming process during the start-up of the system and a node test phase during a free-passenger state of the conveyor. This wire is used to implement a daisy-chain process between nodes.

3. Slave receiver/emitter node implementation

For the implementation of the slave receiver and emitter node, several solutions were evaluated (figure 3).

Integrated CAN and Stand-Alone CAN solutions must have a Microcontroller and this increases the cost of every node. The selected solution is based on a MICROCHIP 250xx CAN I/O Expander chip that offers the needed capabilities with a low cost (figures 4 & 5).

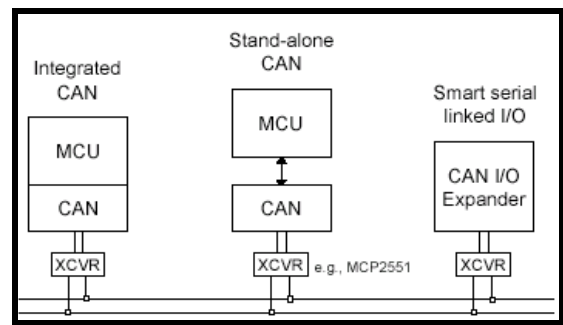

Figure 3: Different solutions for SLAVE nodes implementation.

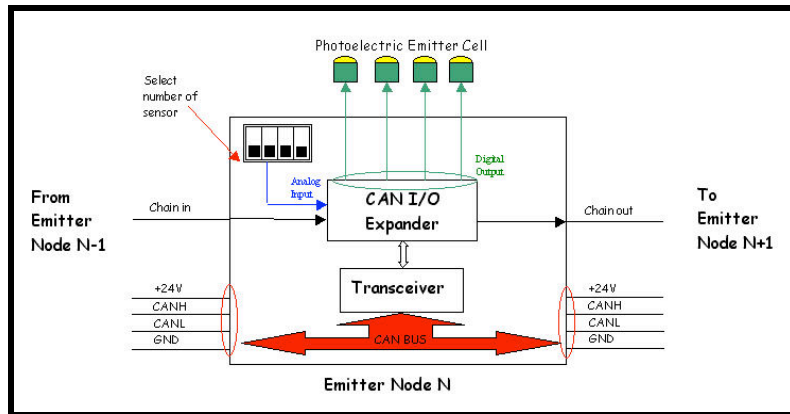

Figure 4: Emitter Node Structure.

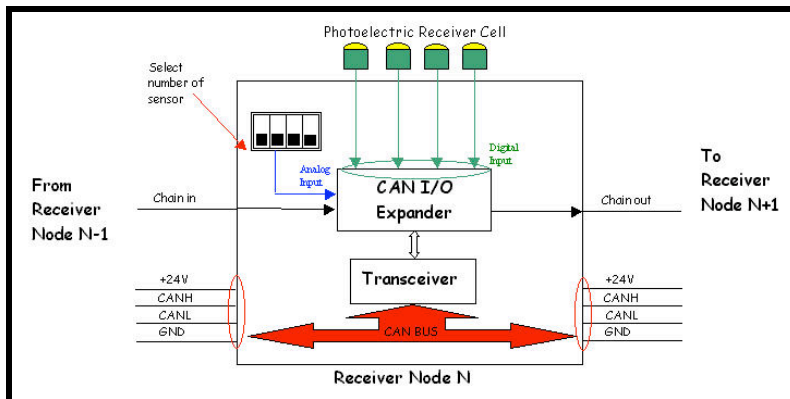

Figure 5: Receiver Node Structure.

The main disadvantage of using nodes based on MICROCHIP CAN I/O expanders is its low grade of programmability. This low programmability disables us to use automatic node discovery procedures in CAN as described in [4]&[5].

Every CAN I/O expander chip has eight general purpose I/O lines individually selectable as inputs or outputs. These eight pins are distributed in the following mode:

- Four pins are used as outputs or inputs to control the 4 emitters or 4 receivers respectively.
- One pin is a daisy-chain input from the previous node in the network. If this input is low, the CAN I/O expander is reset.
- One pin is a daisy-chain output to the following node in the network. This output is high when the system wants to activate the following node.
- Another pin is used as analog input. It helps to know how many cells (1 to 4) are connected to the node.
- The last pin is used only in the last node of the chain to indicate that it is a terminal node of the network.

All slave nodes are programmed initially with the same configuration, filters and input/output messages, but all are reset initially. The master node deactivates the reset input of the first node in the network. Now, this first slave node is the only one which is ON-BUS. Then, the master node can re-programme all input/output and filters registers of this first node. The last programming stage of this first node is to activate the daisy-chain output. In this way, the second node in the chain is ON-BUS now and then, it can be re-programmed by the master node in the same way that the first was. The first node is not affected by the messages sent by the master node to the second slave node because its filters and inputs messages had been re-programmed to different values previously. In the same way, the rest of the slave nodes in the network can be reprogrammed. The input and output messages are different for every slave

node and so, the master node sends frames independently and receives different messages from every slave node.

Four pins in the emitter slave node are programmed as outputs. They are committed to turn-on and turn-off the photocell emitters.

Moreover, the CAN I/O expanders used in the receiver nodes are configured to send messages every falling edge occurred in one of the four receiver input pins. So, when a photoelectric beam has been cut because someone or something has crossed it, an automatic message is sent by the receiver slave node to the master node.

CAN I/O expanders have an error management logic [6] which is responsible of the fault confinement of the CAN device. It has two counters: Receive Error Counter (REC) and Transmit Error Counter (TEC). If at least one of the error counters equals or exceeds 128, the device is set to a Error-passive state, where the device can not transmit.

This error state is dangerous from the point of view of the conveyor system because it can lead to a situation with people cutting photoelectric beams but any node sending messages to the master node. To avoid this dangerous situation, the master node must avoid that any slave node was set to this error-passive state. Hence, the master node is continuously asking the slave nodes for the values of the error counters. To do it, the master node sends a "Read CAN error" information request message to every slave node. If some node answers with a "Read CAN error" output message and this message has an error counter data greater than 90, the master node resets all system and put its relay output in the same state as if the conveyor was passenger busy. Afterwards, it tries to start-up the system again.

4. Máster node: state diagram algorithm.

The Master node is the system core, because it controls all slave nodes and must know if some photoelectric beam is cut off or working badly. It is based on a 8 bit mid-range PIC microcontroller with a complex firmware. The firmware has been implemented following a state diagram structure as is shown in figure 6.

State S0 is a power-up state used by the main node to configure the CAN controllers and to set an initial value for the output signals of the master node.

State S1 is an emitter node configuration state where different messages are assigned to every CAN emitter node. The daisy-chain IN/OUT wires are used during this phase to activate every emitter node in an independent way.

State S2 is a receiver node configuration state similar to state S1. But, in this case, the CAN I/O expanders configure their pins as inputs instead as outputs and automatic transmission is carried out every time a digital input edge is detected in one of the four digital receiver inputs. Different messages are also assigned for every receiver node.

At the end of state S2, all nodes are completely configured, but the system is not operative and it must indicate as if the escalator or moving walk was passenger busy. Moreover, the photoelectric beams of the curtain have not been reviewed yet.

Hence, an operation test of the right operation is carried out during State S3. The right operation of all light beams is verified. A simple way to carry it out is turning off every emitter and test if an automatic falling edge message of the corresponding photo receiver is obtained. If all beams are working well, it passes to state S4. If any beam is not working appropriately, it passes to an error state S10.

As every node has its unique messages and the data included in every frame gives information about which beam has been turned off, the correspondence between turn-off emitter and receiver edge can easily be detected.

State S4 is the normal operation state, where the system is waiting for a light beam to be cut off. So, the master node is waiting for automatic edge messages from a receiver node. Nevertheless, due to the safety system requirements, even if there are not any cut off beams, the photoelectric detectors and the node communication must be tested. The photoelectric detectors are almost continually tested in a similar way that was described for state S3. The node communication is tested in a regular time-base way. This test is also used to get the error counter values of the CAN I/O expander of every slave node. If a fault is detected, the system passes to state S10 where the conveyor is shown as passengers busy. After a watchdog timeout, the system can be reset and a new start process from state S0 can begin.

If during State S4, some electron beam is cut off and an automatic edge message is sent by a receiver node, the system passes to state S5. In this state, a adjusted timer is executed. It can be several seconds, the value depends on the conveyor length and speed. If during this timer, another light beam is cut, the timer will start again. When the timer ends, the system passes to state S6, where a test of the photoelectric detectors and node communication is carried out. The test is carried out in a similar way as in State 3. During this state, the system marks the escalator is still passenger busy. If the test is OK, the system passes to state S4 where the conveyor is marked as passenger empty and the motor drive can start-up or stop the escalator or moving walkway freely without dangerous situations.

State S10 is an error state that is reachable when some fault has been detected in other states. A little timer is carried out in this state and when the timer

ends a start-up process from state S0 is started again.

The assembled master node (figure 7) has an LCD to display information about the system state and about whatever fault

detected, including node number and photocell number. In this way, the bad-working node or photocell can be detected quickly and the maintenance service is made easy.

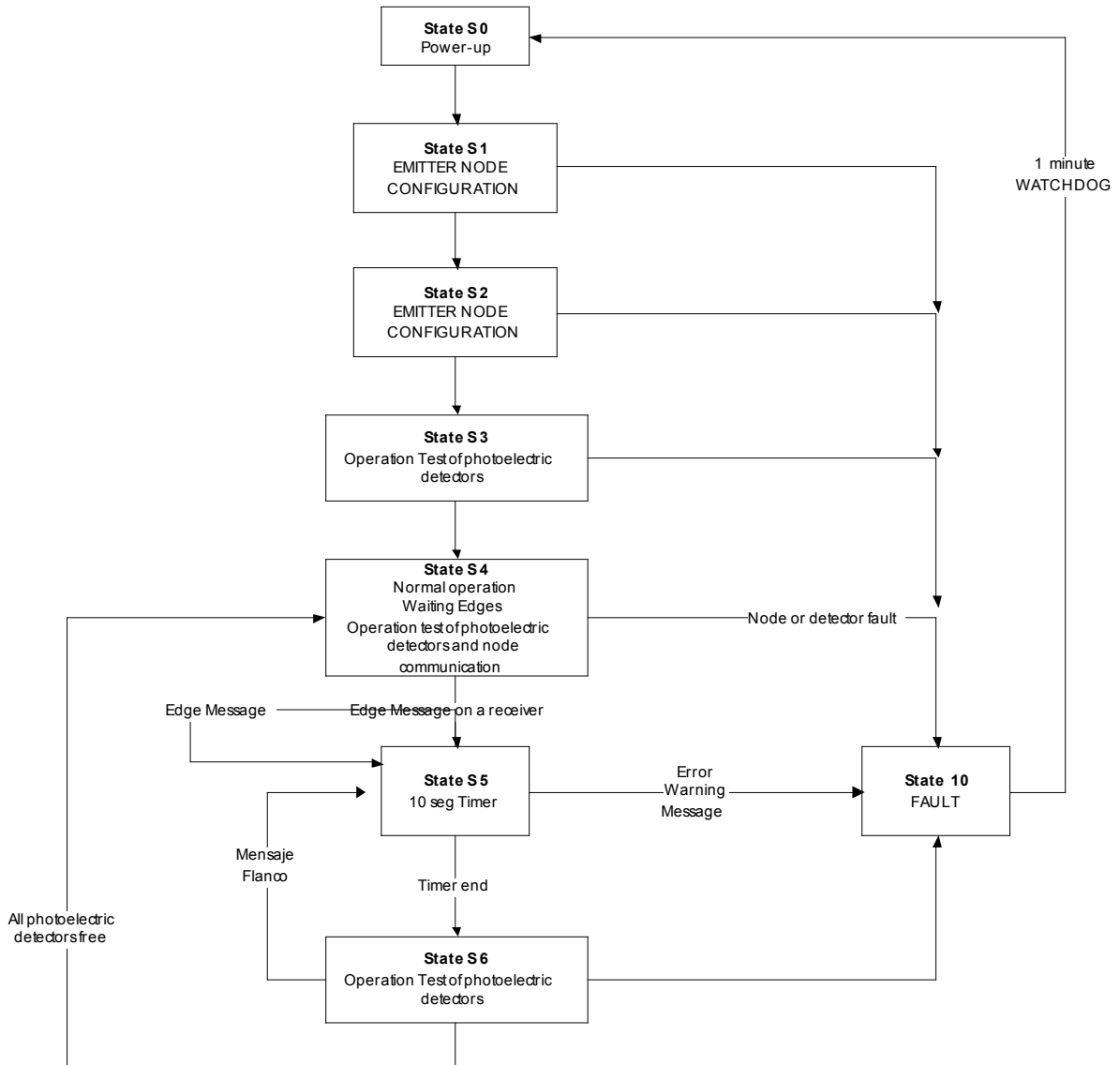

Figure 6: State diagram for the master node.

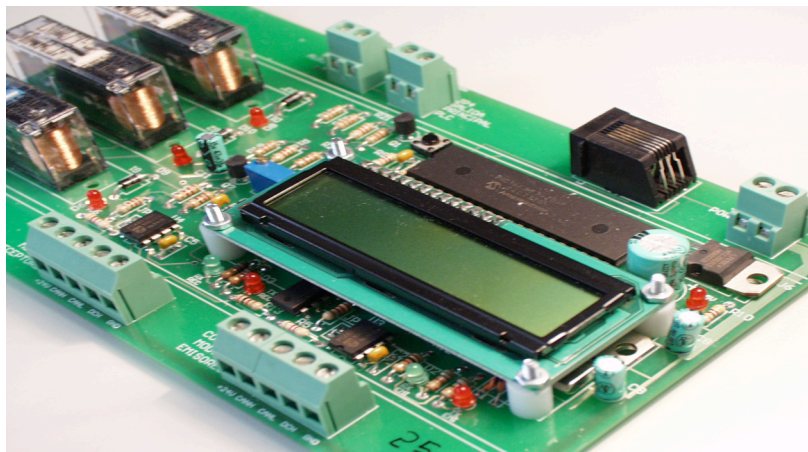

Figure 7: A master node prototype photo.

Conclusions and brief description of other projects based on the same technology.

A very low cost solution based on CAN I/O expanders to detect passengers in escalators and moving walkways are described in this paper. The structure is based in a microcontroller embedded master node based and a quite big number of slave nodes with I/O expanders. The number of slave nodes is only limited by the CAN transceiver characteristic and so, very long escalator can be covered using this system

The main advantages are the very low cost and repetition viability of the slave nodes. The disadvantage of programmability due to use of CAN I/O expanders in the slave nodes instead of using a microcontroller based solution can easily be diminished if a little more complex algorithm in the master node is implemented. This solution fulfills most standard safety requirements for escalator

and moving walks. This philosophy of design based on low cost nodes with CAN I/O expanders and a MASTER node can be applied to other types of system on escalator and moving walks. For instance, our group has developed a Cold Cathode Fluorescent Lamp (CCFL) Ballast for use on escalators and moving walks. It is fitted with a CAN interface based on CAN I/O expander. Using this CAN bus, the central control unit of the conveyor can turn on or turn off the lamps according to some type of light sensor or timer. It can also detect when some CCFL ballast is working badly and , even, if the central unit is fitted with some type of modem-based communication, the fault can be communicated to the maintenance service. Figure 8 displays a photo of a prototype showing a very thin CCFL ballast board and two small boards: one for the protection circuits and other for the CAN interface.

This implementation is patent pending.



Figure 8: Photo of the 3 boards (ballast/base, CAN and protection circuits).

Author 1: Francisco Fernández Linera
Company: DIEECS – Universidad de Oviedo
Address: Campus de Viesques. Edif. Dep.
3. 33204- Gijón (SPAIN)
Phone: 34 985182565
Fax: 34 985182138
E-mail: linera@uniovi.es
Website: www.ate.uniovi.es

Author 2: Francisco J. Garcia Navas
Company: Universidad de Oviedo /
TRESA Elevators
E-mail: fran@ate.uniovi.es

Author 3: Javier Cardesin Miranda
Company: Universidad de Oviedo
E-mail: cardesin@ate.uniovi.es

Author 4: Juan Martin Ramos.
Company: Universidad de Oviedo
E-mail: juan@ate.uniovi.es

Author 5: Fernando Nuño Garcia
Company: Universidad de Oviedo
E-mail: fnuno@uniovi.es

References

- [1] United States Patent. Number 5,704,464. Passenger sensor for an escalator or moving walk. OTIS ELEVATOR COMPANY
- [2] United States Patent. Number 5,992,604. Switching arrangement for returning a people-conveying device to a state of readiness. KONE
- [3] European Patent. Number 03026700.9. Control Apparatus for passenger conveyor and passenger detecting device. MITSUBISHI DENKI KABUSHIKI KAISHA.
- [4] Y. Yellambalase & M. Choi. Automatic Node discovery in CAN controlled using reserved identifier bit. IMTC 2007 Instrumentation and Measurement Technology Conference.
- [5] G. Cena & A. Valenzano. A protocol for Automatic node discovery in CANOPEN networks. IEEE Transactions on Industrial Electronics, Vol. 50, n°3, June 2003.
- [6] MICROCHIP, “MCP2502X/5X CAN I/O Expander family Datasheet”.